

0

1

2

3

4

5

A

VW Käfer 1200 mit Elektroantrieb

B

C

Käfer 1200

technische Daten:

Fgst.Nr. 119 159 972

D

kurzer Vorderwagen

Schräglenker

E

'66er Optik

- Tesla Small Rear Driveunit
- Leistung 100kW (max Leistung: 220 kW, 330 Nm)
- 36,96 kWh Batteriekapazität (netto) (Second Life Batterie VW)
- 10 Module hinten (Kofferraum), 4 vorne (Kofferraum)
- 6,6 kW AC Ladeleistung (2-phasig)
- Motorhalter, Batterieboxen etc. in Wagenfarbe gepulvert
- Ansteuerung der originalen Tankanzeige
- Batteriemangementsystem
- ø108mm Antriebswellen
- original Gaspedals bleibt erhalten
durch speziell entwickelte Pedalbox mit Gaskurvenverstellung
- CCS-Kit für schnelles laden durch Wasserkühlung Batterien
- Heizung über Hochvoltwärmetauscher (Wasser)

F

G

H



Author: Fuss-im-Ohr

Datum: 17.12.23

Smarti Schaltplan

Projekt: Käfer

Seite: 1/32

	0	1	2	3	4	5	6	7	8	9	10	11	12	13	14	15	16
A	<ul style="list-style-type: none"> * A – Steuergerät * B – Umsetzer von nichtelektrischen Größen auf elektrische Größen (zum Beispiel Temperaturfühler) * C – Kondensator (Elektrotechnik) Kondensatoren 																
B	<ul style="list-style-type: none"> * D – binäre Elemente, Speicher (zum Beispiel Bordcomputer) * E – Verschiedenes (Heizeinrichtung, Klimaanlage, Leuchte, Zündkerze) * F – Sicherung * G – Generatoren, Autobatterie, Stromversorgung * H – Meldeeinrichtungen (Signalleuchten, Kontrollleuchten) 																
C	<ul style="list-style-type: none"> * K – Relais * L – Induktivität (zum Beispiel Spule) * M – Motoren * N – Regler, Verstärker 																
D	<ul style="list-style-type: none"> * P – Messgeräte, Prüfeinrichtungen * R – Widerstand (Bauelement) Widerstände * S – Schalter, Taster * T – Transformatoren * U – Modulatoren (zum Beispiel Gleichstromwandler) 																
E	<ul style="list-style-type: none"> * V – Halbleiter, zum Beispiel Diode, Transistor oder (historisch) Elektronenröhre * W – Übertragungsweg, Leitung, Antenne * X – Klemmen, Stecker, Steckverbindungen * Y – elektrisch betätigte mechanische Einrichtungen (zum Beispiel Einspritzmagnetventil) 																
F																	
G																	
H	<p>https://de.wikipedia.org/wiki/Liste_der_elektrischen_Kfz-Baugruppen</p>																



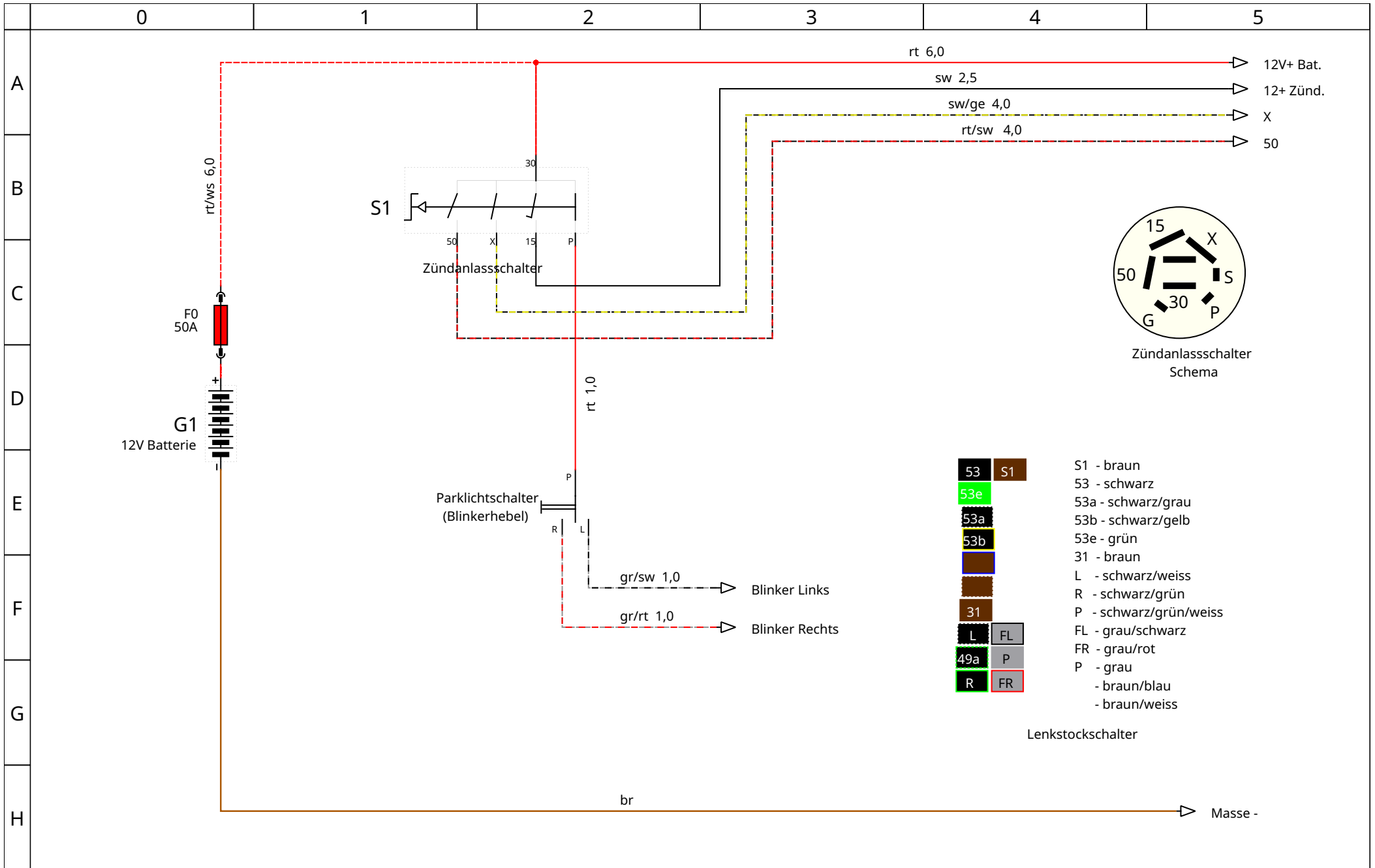

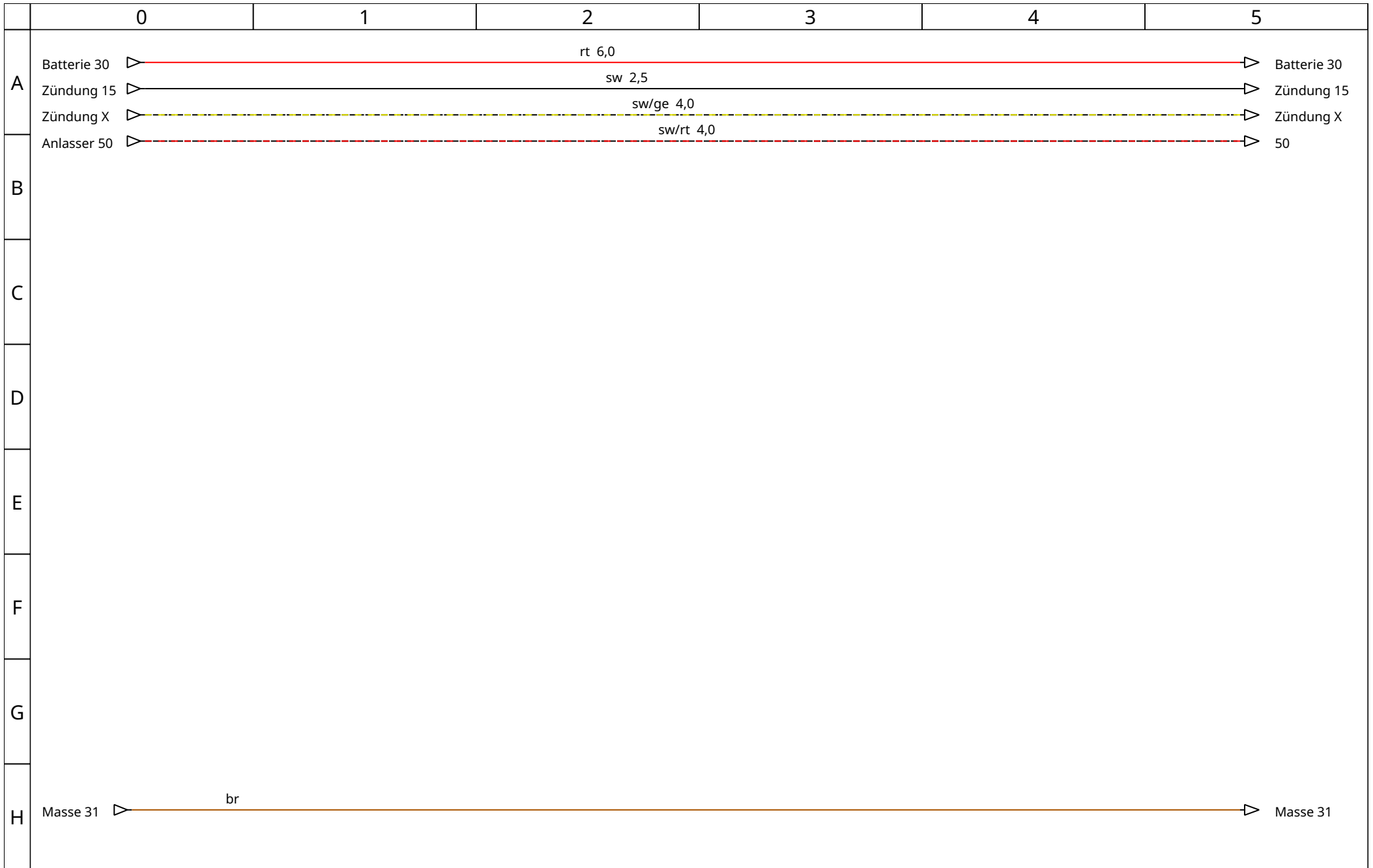

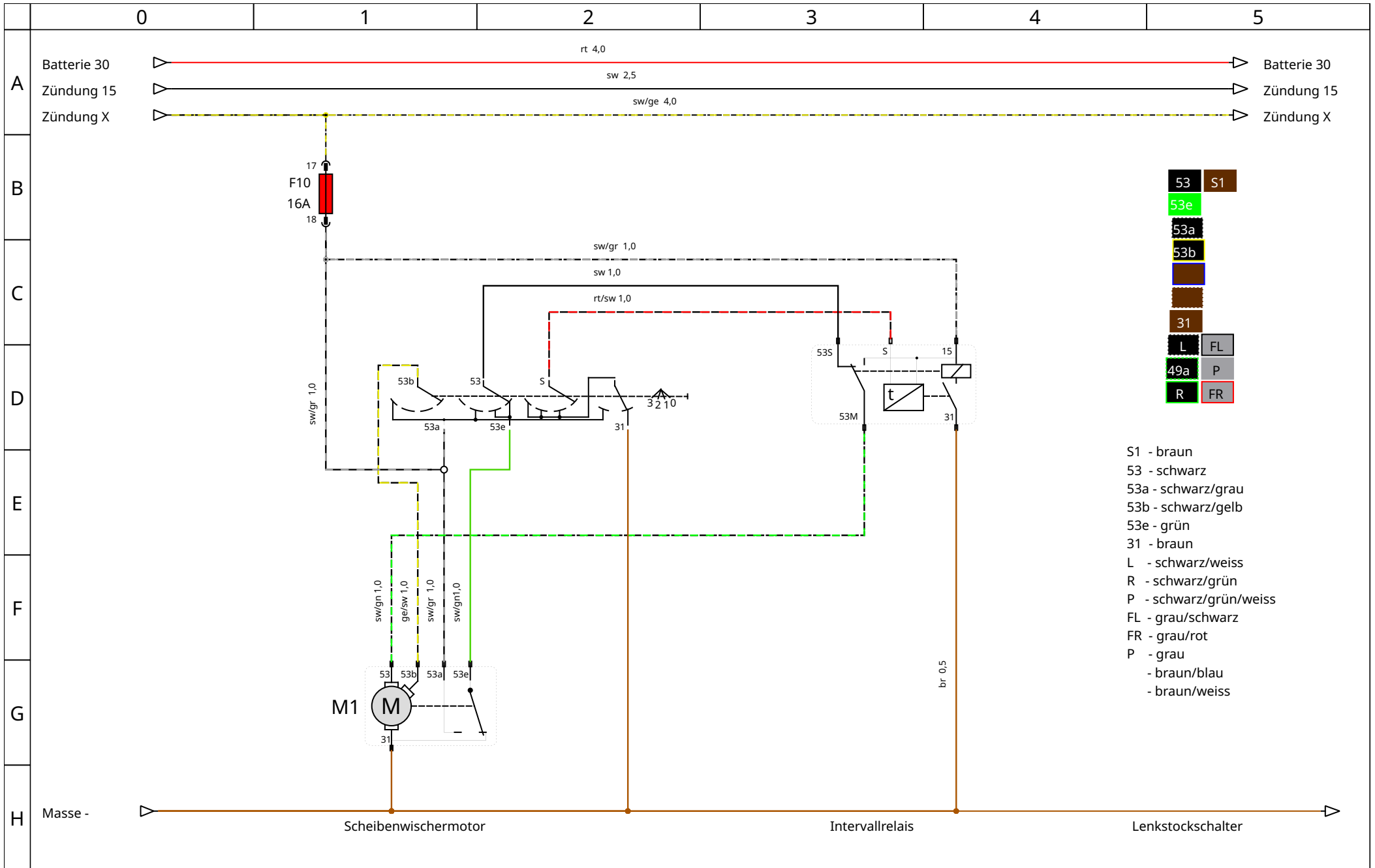

Author: Fuss-im-Ohr

Datum: 17.12.23

Scheibenwischer Intervall

Projekt: Käfer

Seite: 5/32

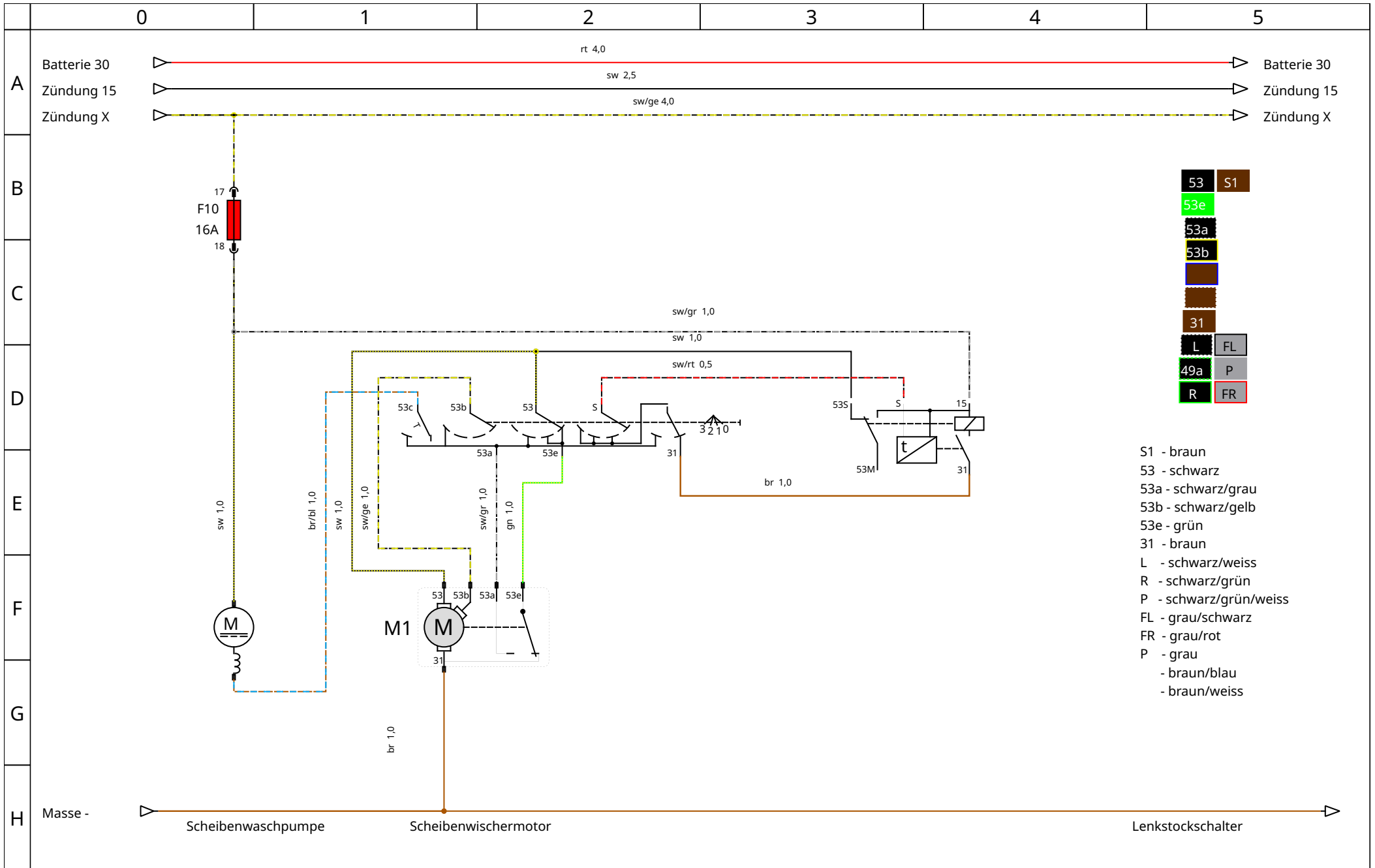

Author: Fuss-im-Ohr

Datum: 17.12.23

Scheibenwischer Intervallschaltung erweitert

Projekt: Käfer

Seite: 6/32



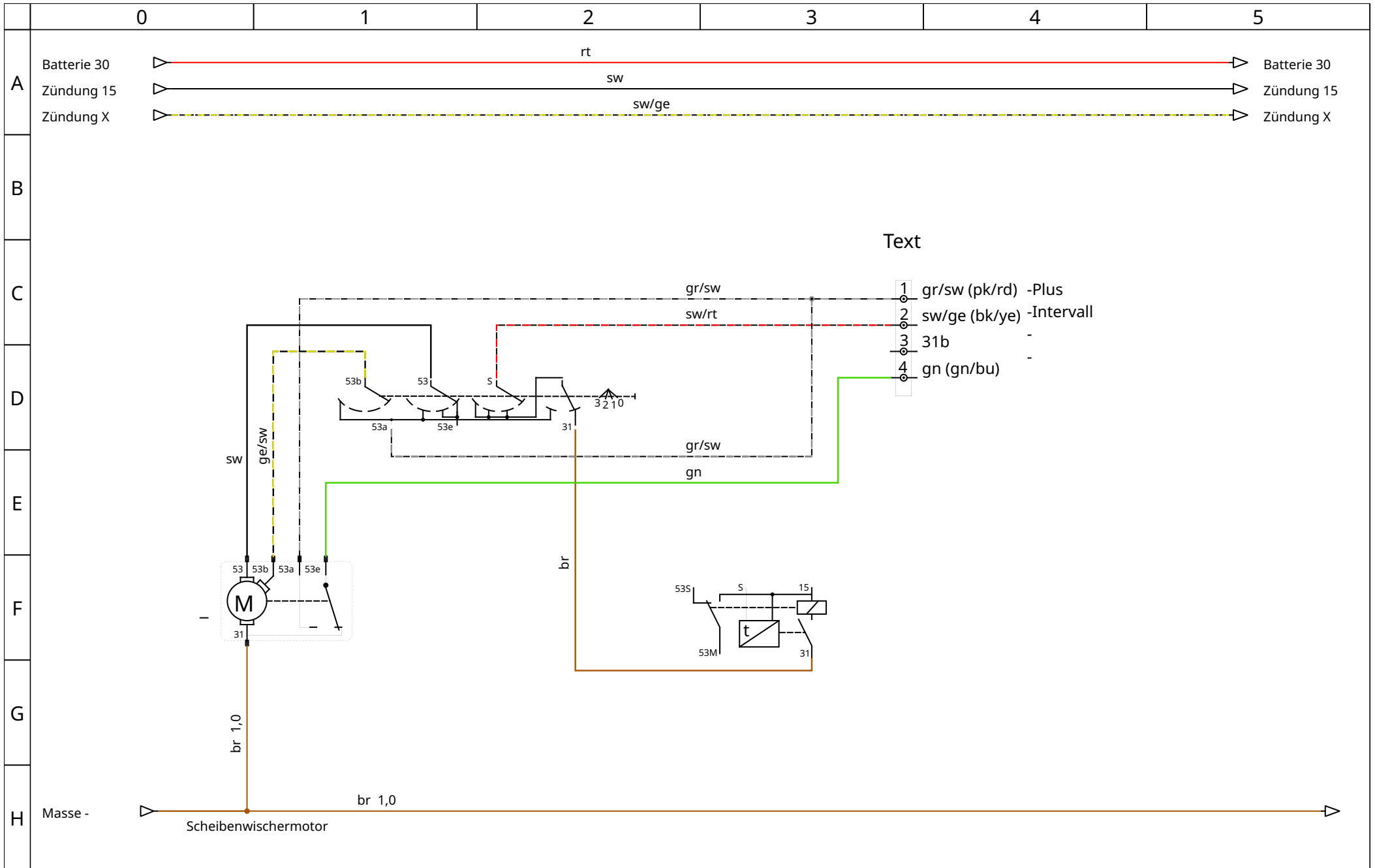

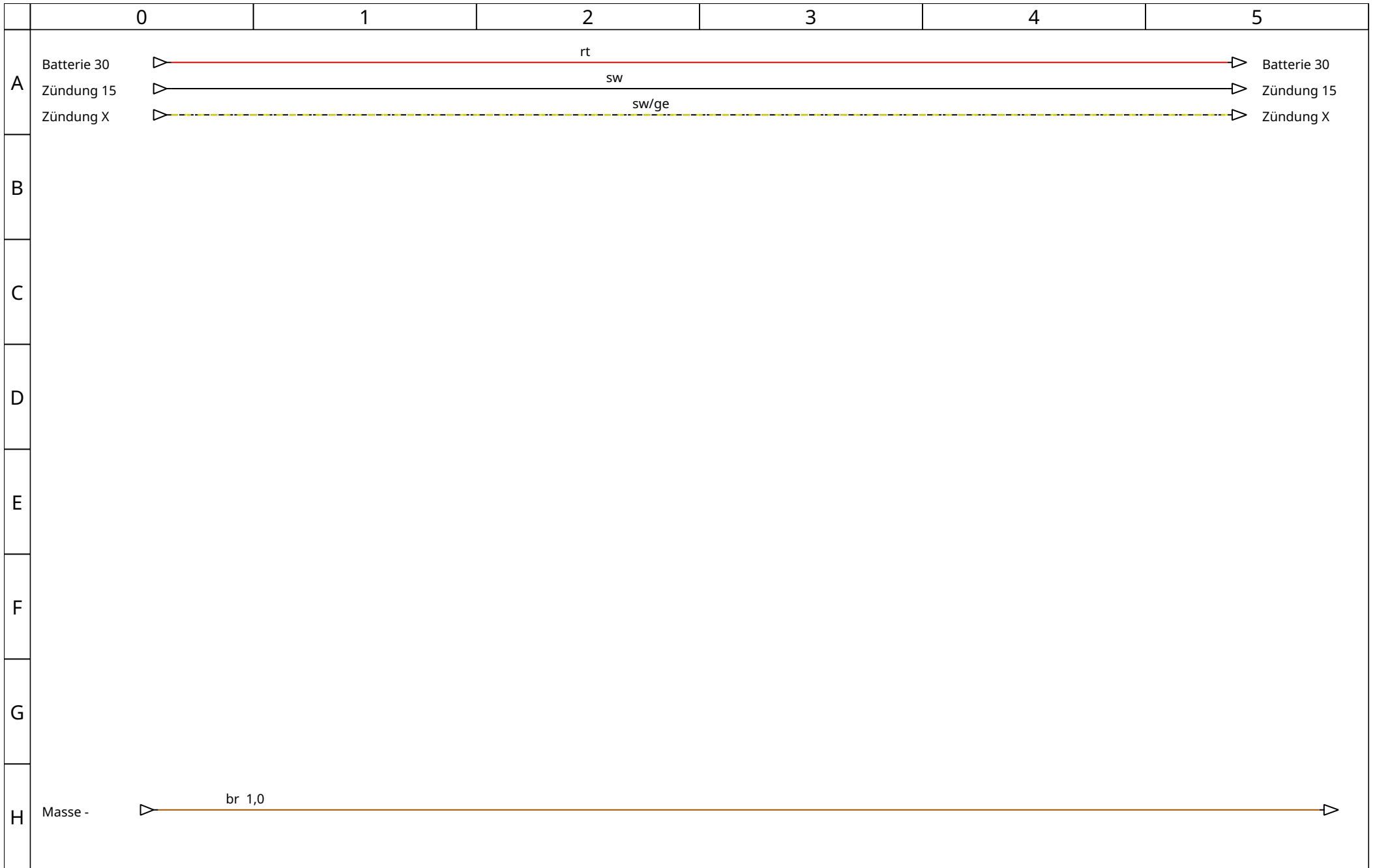

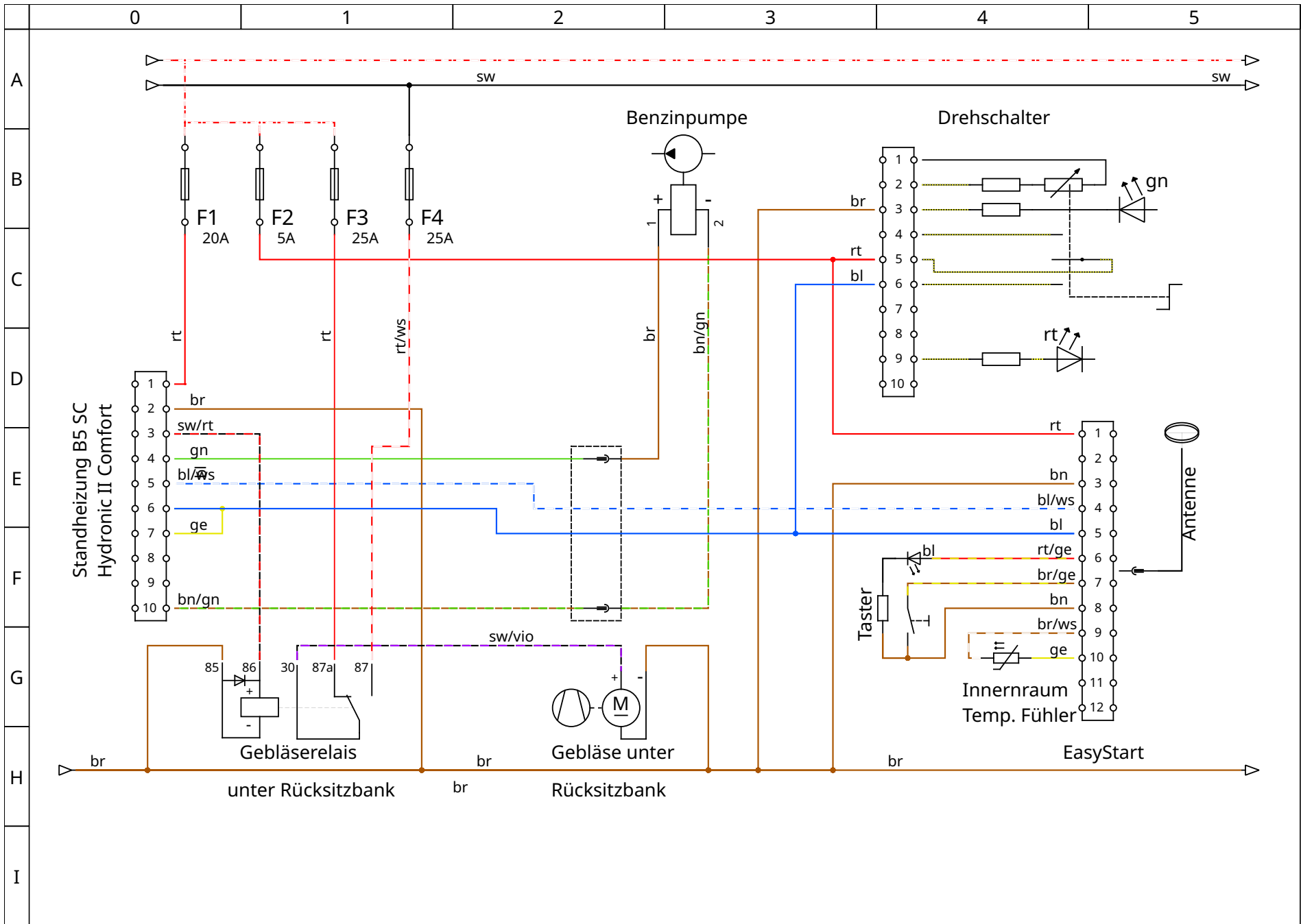

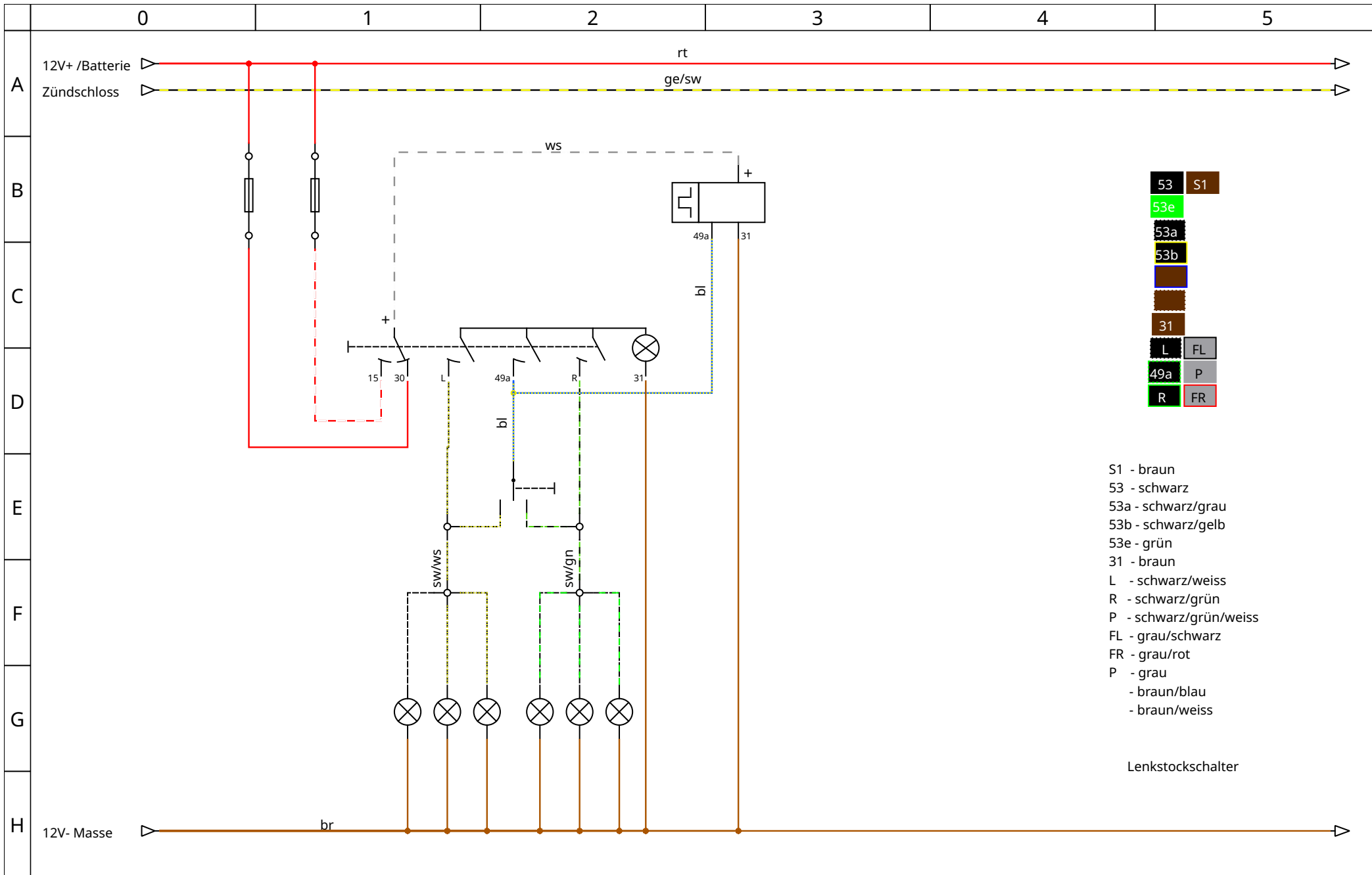

- S1 - braun
- 53 - schwarz
- 53a - schwarz/grau
- 53b - schwarz/gelb
- 53e - grün
- 31 - braun
- L - schwarz/weiss
- R - schwarz/grün
- P - schwarz/grün/weiss
- FL - grau/schwarz
- FR - grau/rot
- P - grau
- braun/blau
- braun/weiss

Lenkstockschalter



Author: Fuss-im-Ohr
 Datum: 17.12.23

Blinker

Projekt: Käfer
 Seite: 10/32

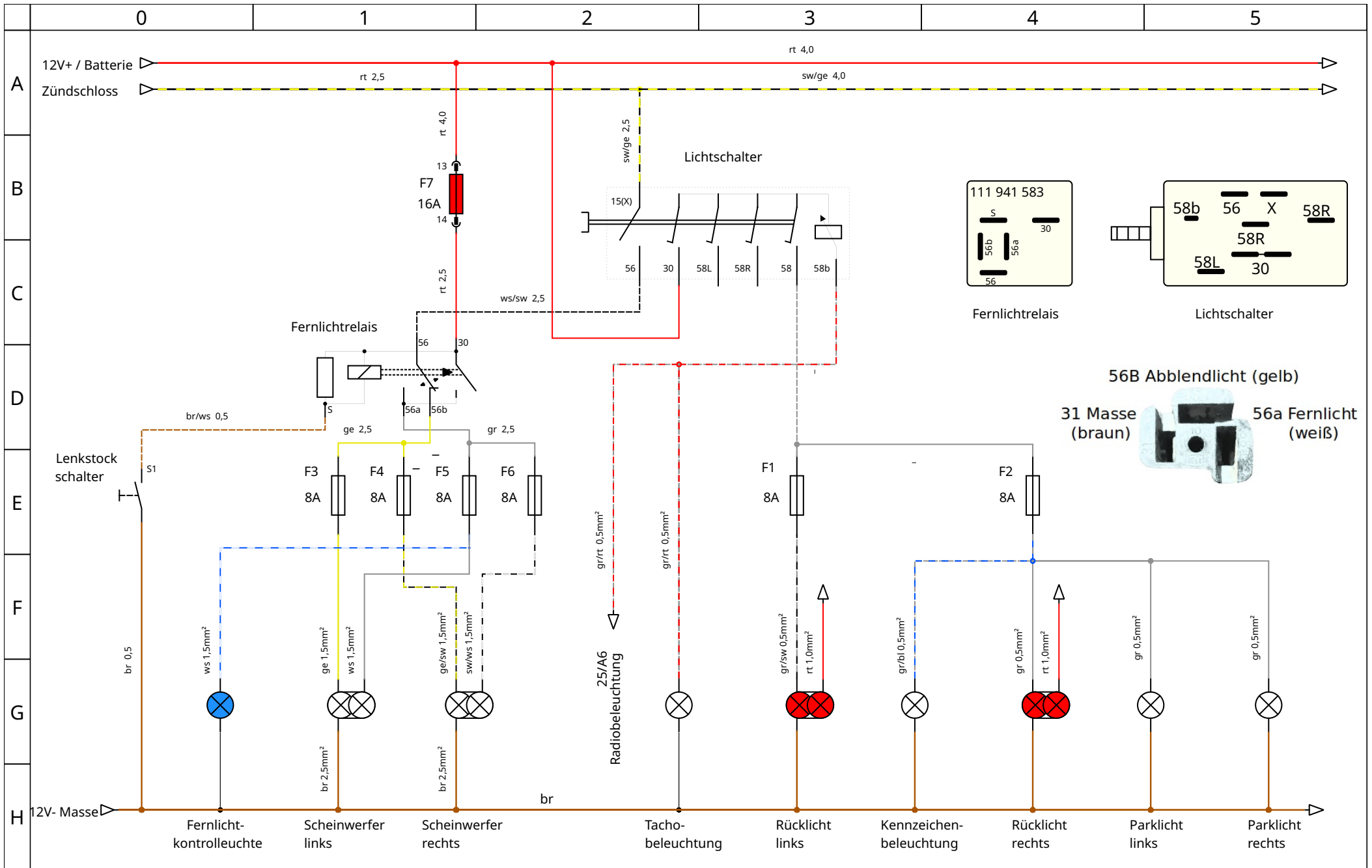

Author: Kulisch
 Datum: 24.12.23

Licht vorne

Projekt: Käfer
 Seite: 11/32

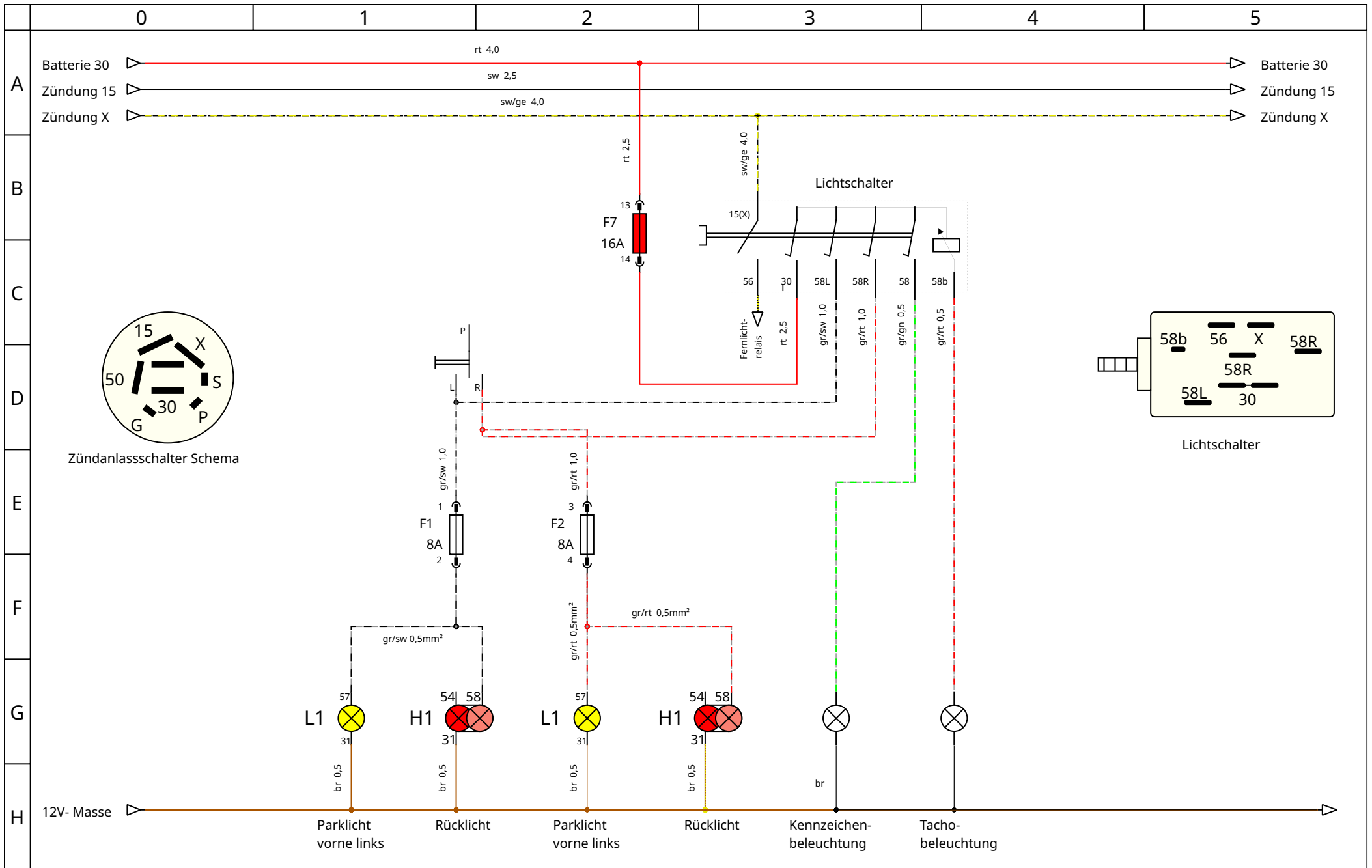

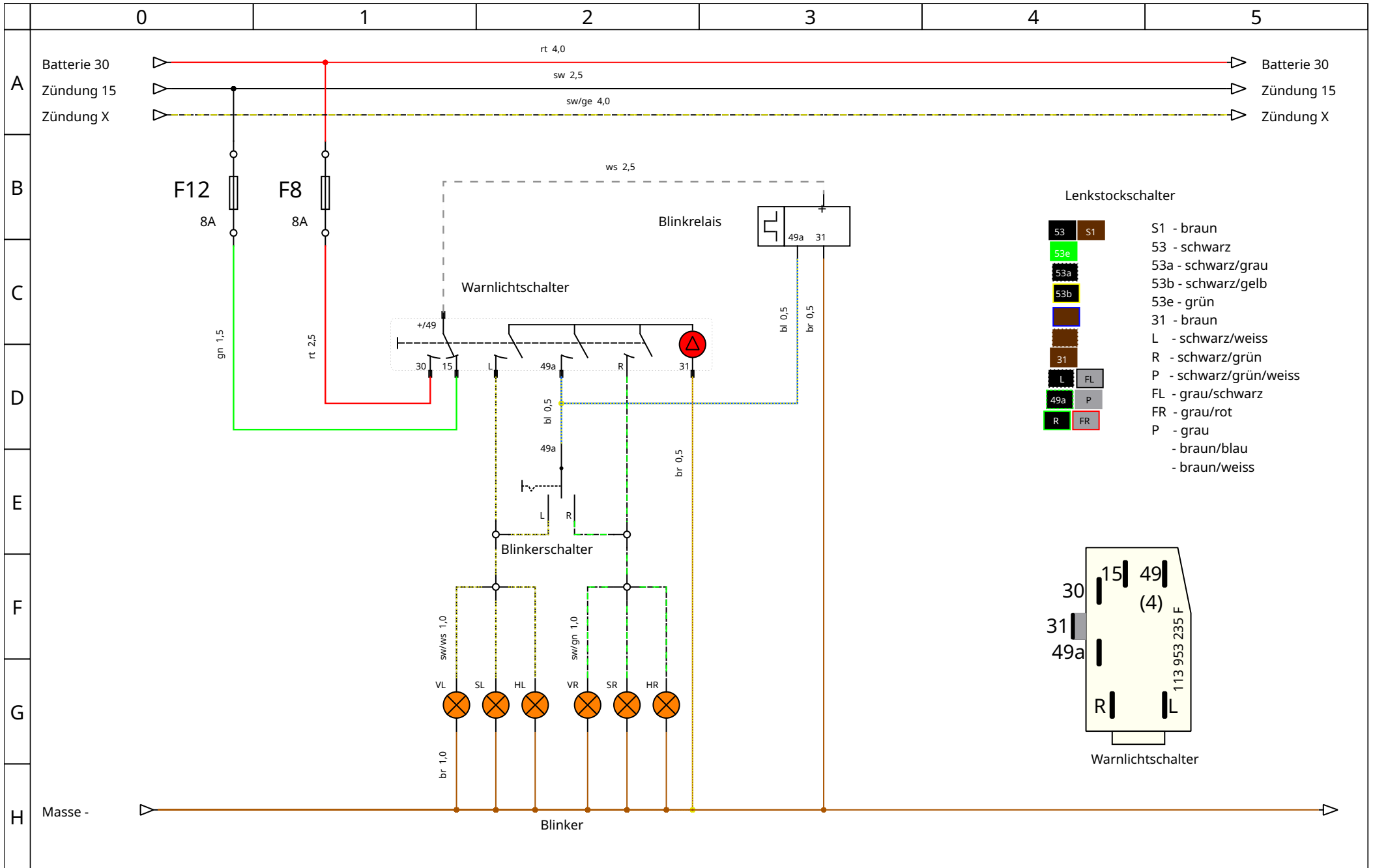

Author: Fuss-im-Ohr

Datum: 21.12.23

Blinker/Warnblinker

Projekt: Käfer

Seite: 13/32



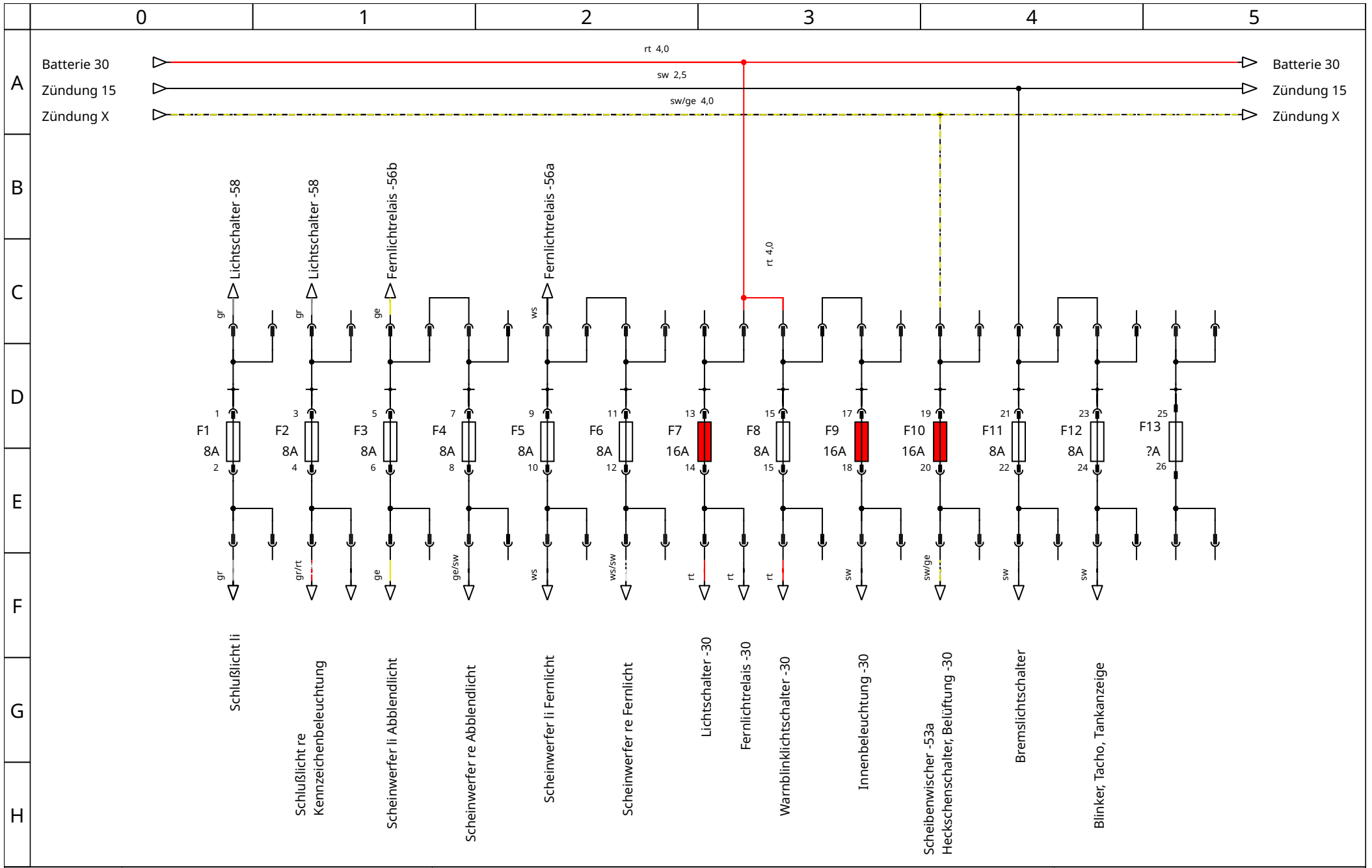

Author: Fuss-im-Ohr

Datum: 21.12.23

Sicherungen

Projekt: Käfer

Seite: 14/32

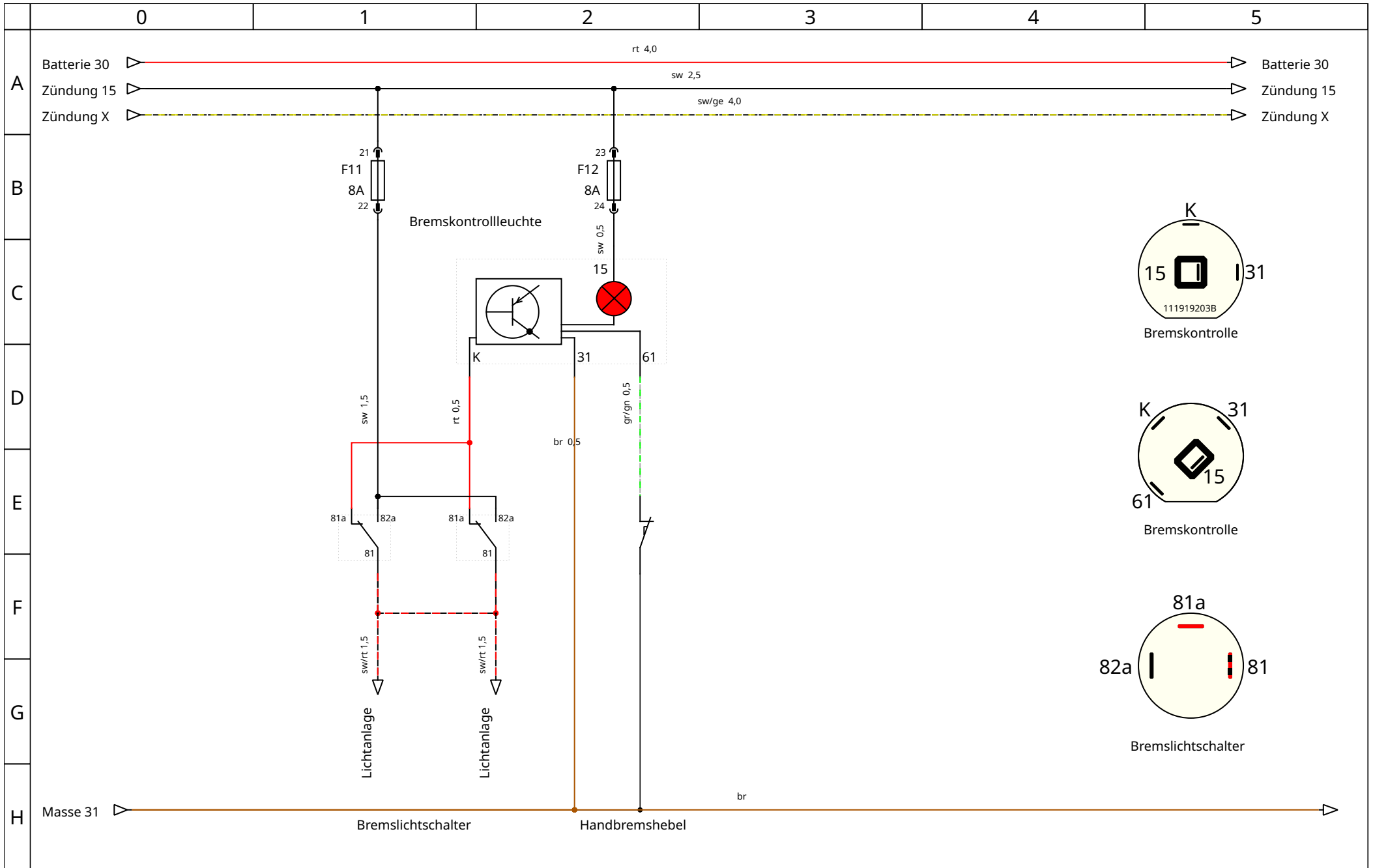

Author: Fuss-im-Ohr

Datum: 24.12.23

Handbremse

Projekt: Käfer

Seite: 15/32

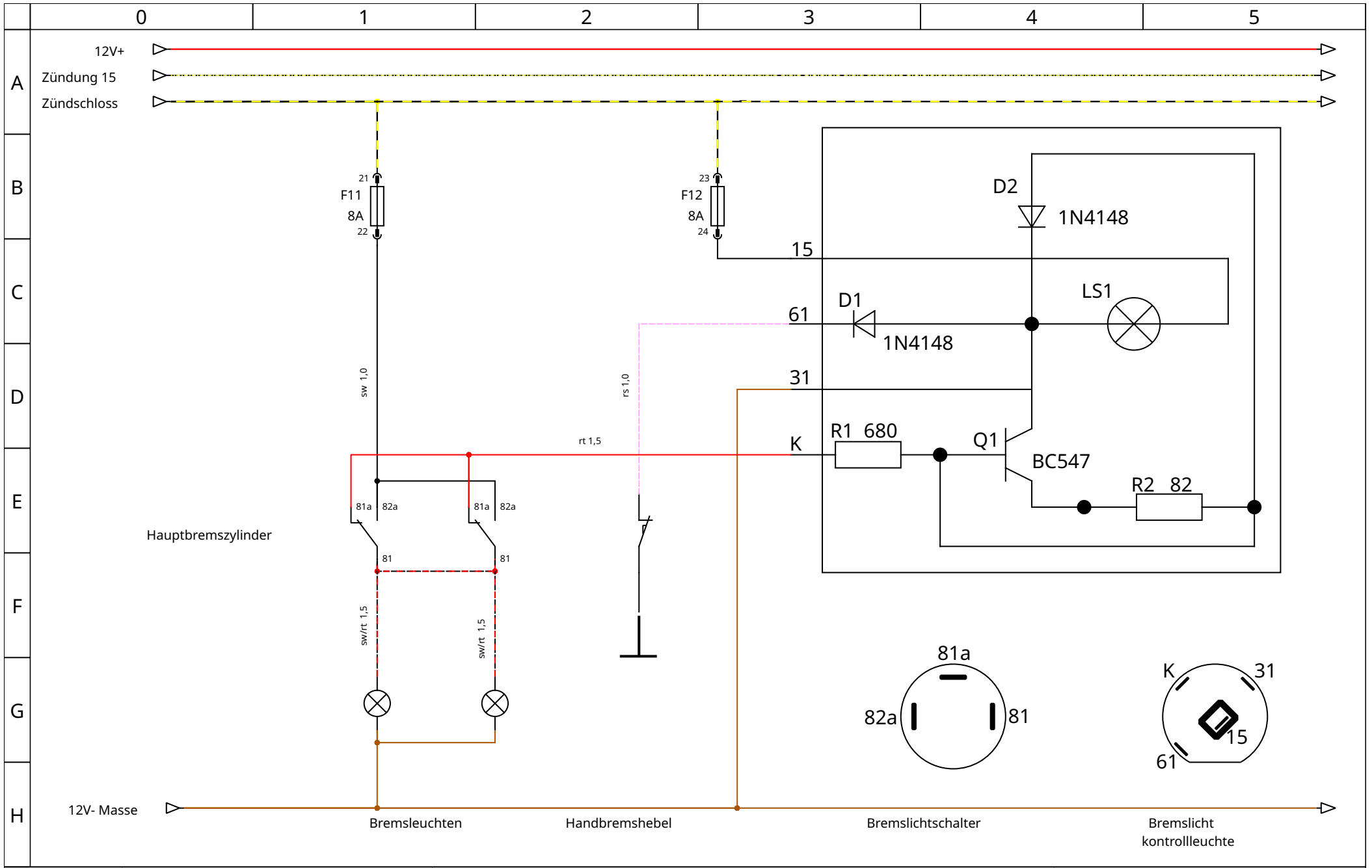

Author: Fuss-im-Ohr

Datum: 21.12.23

Handbremse erweitert

Projekt: Käfer

Seite: 16/32

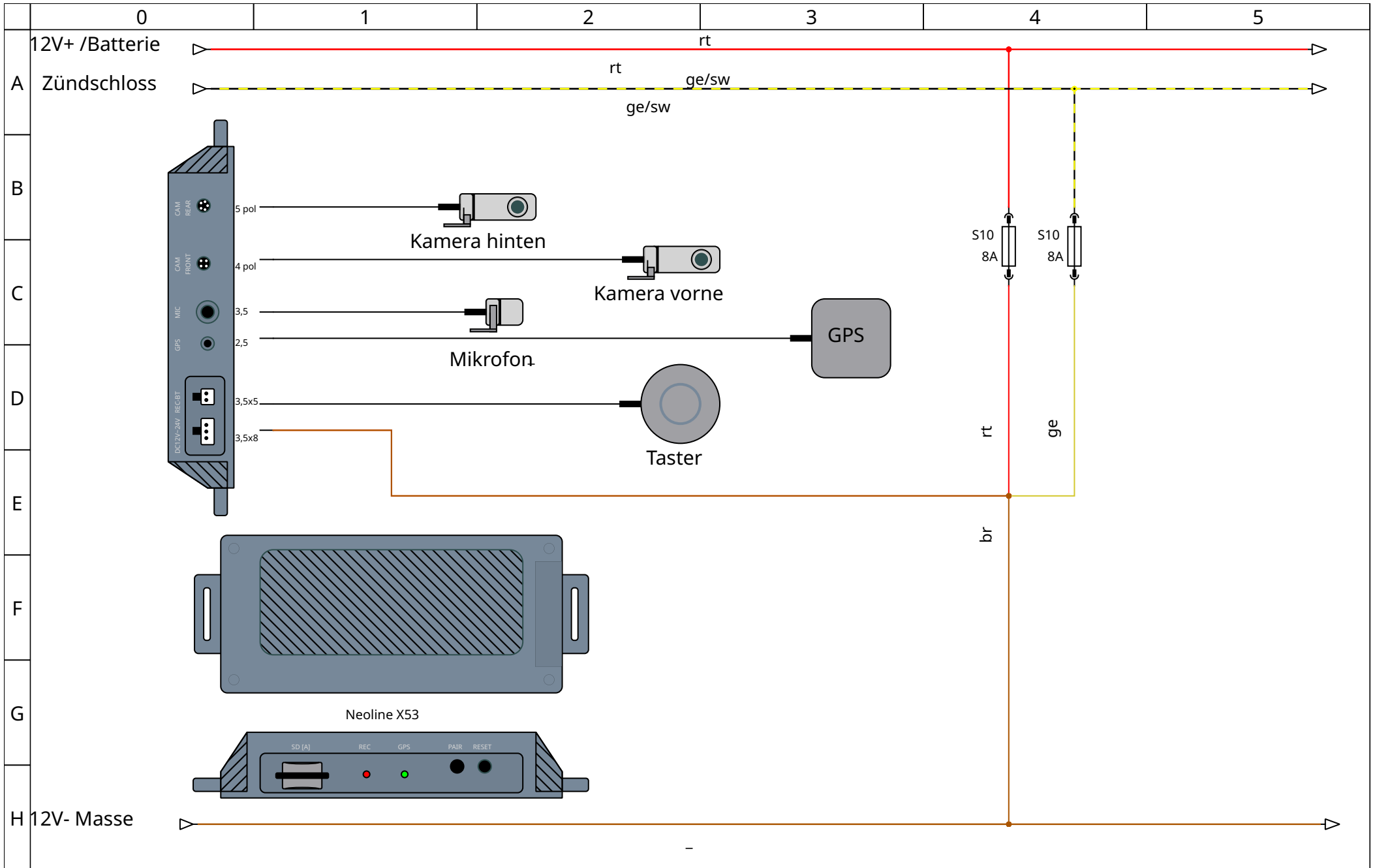

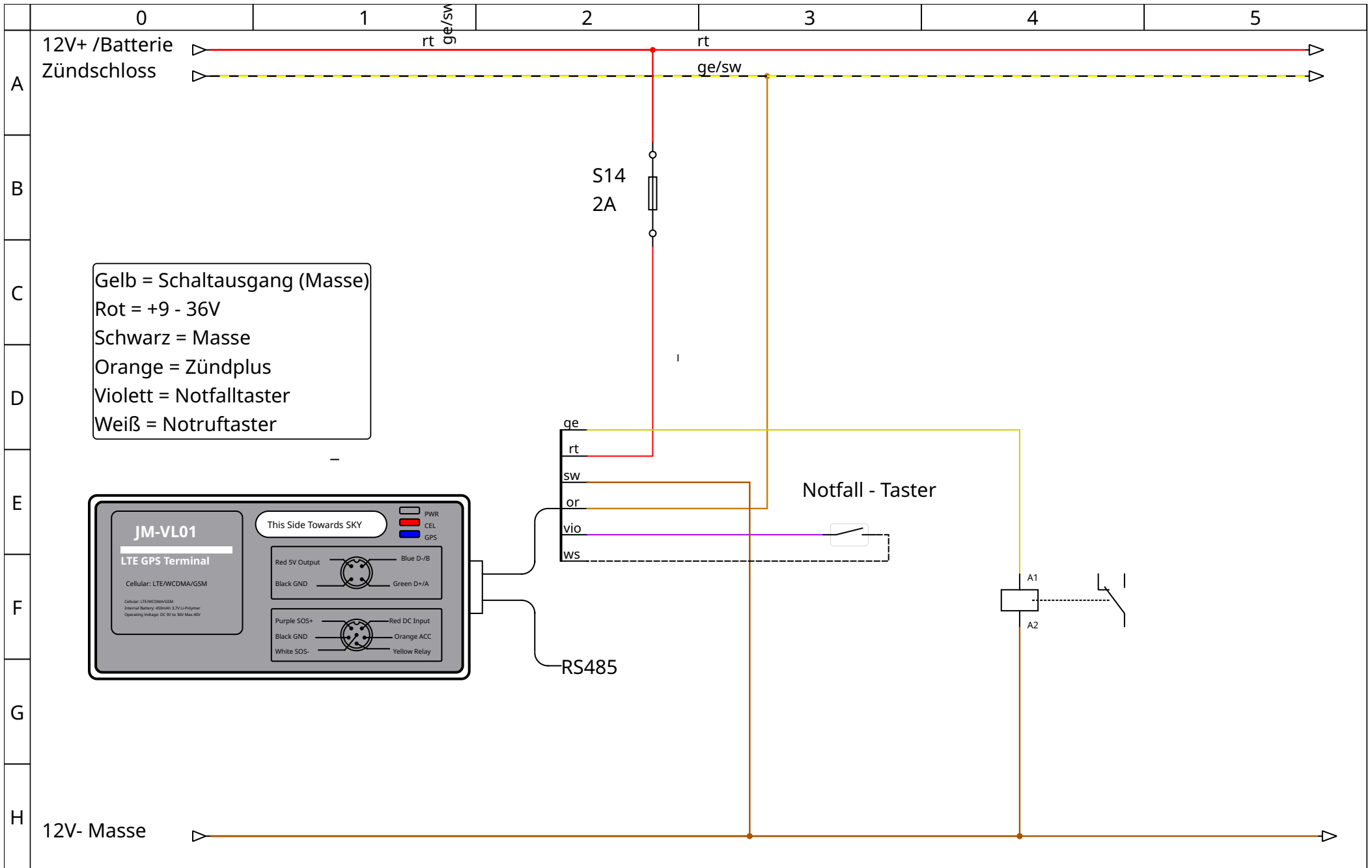

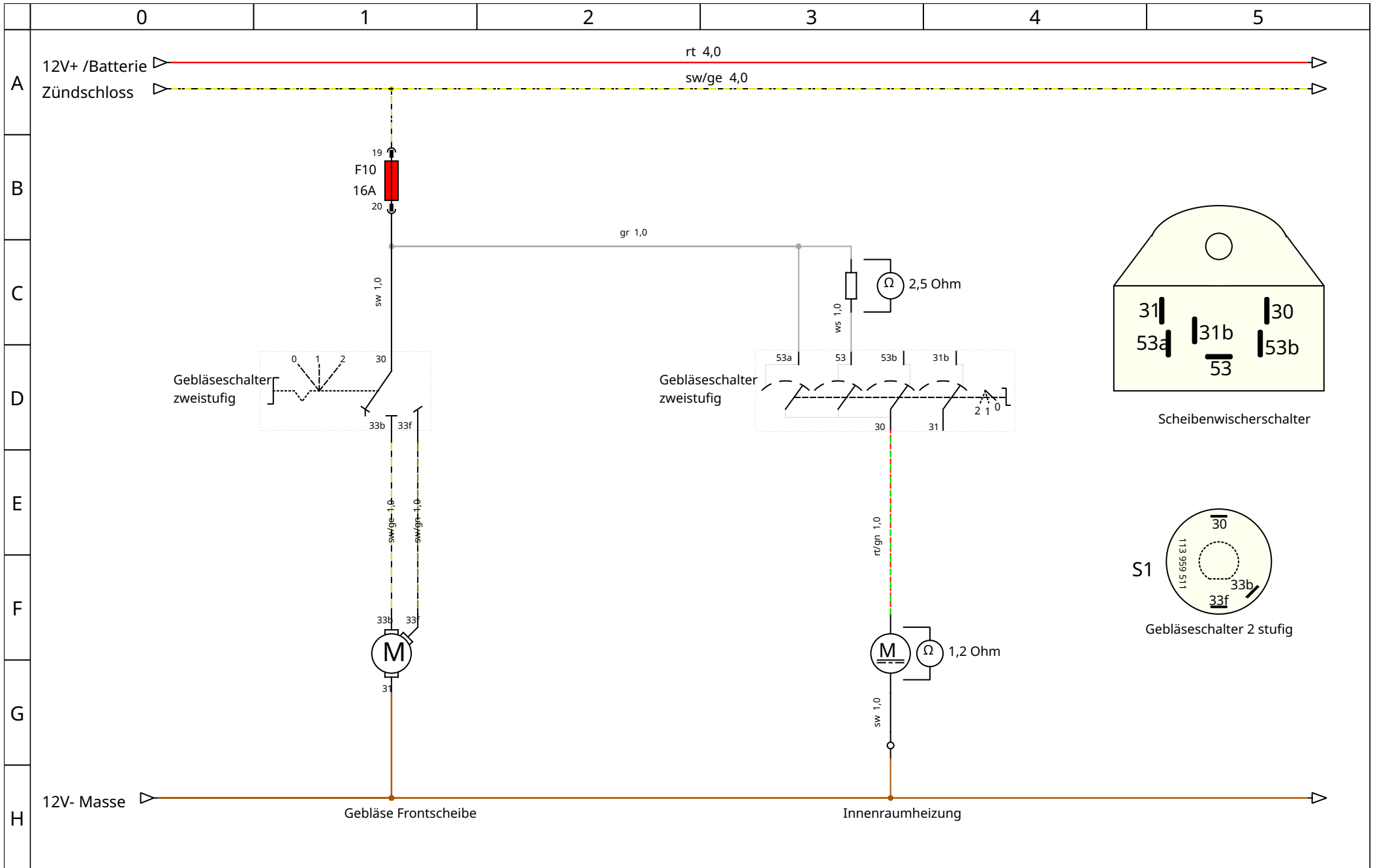

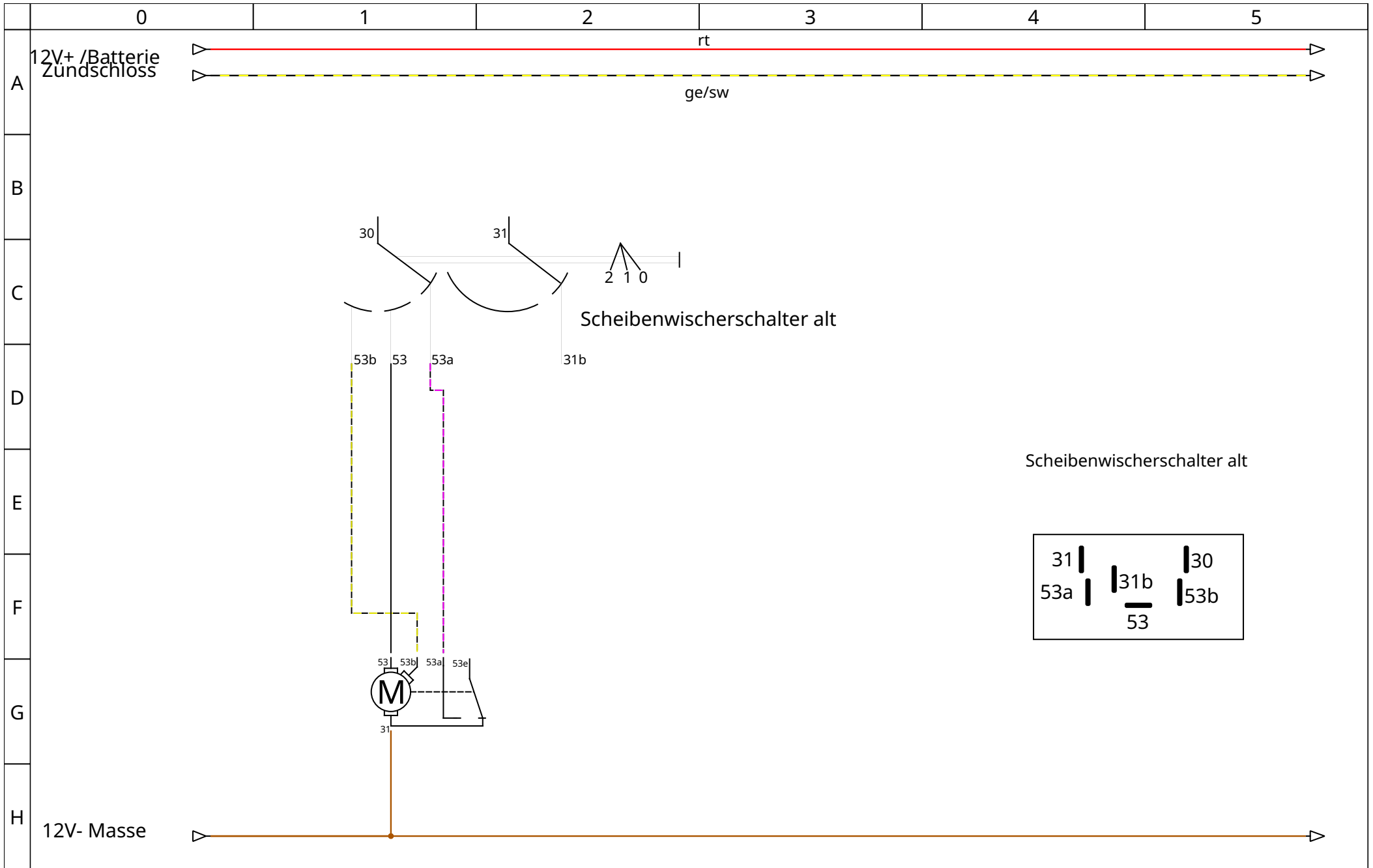

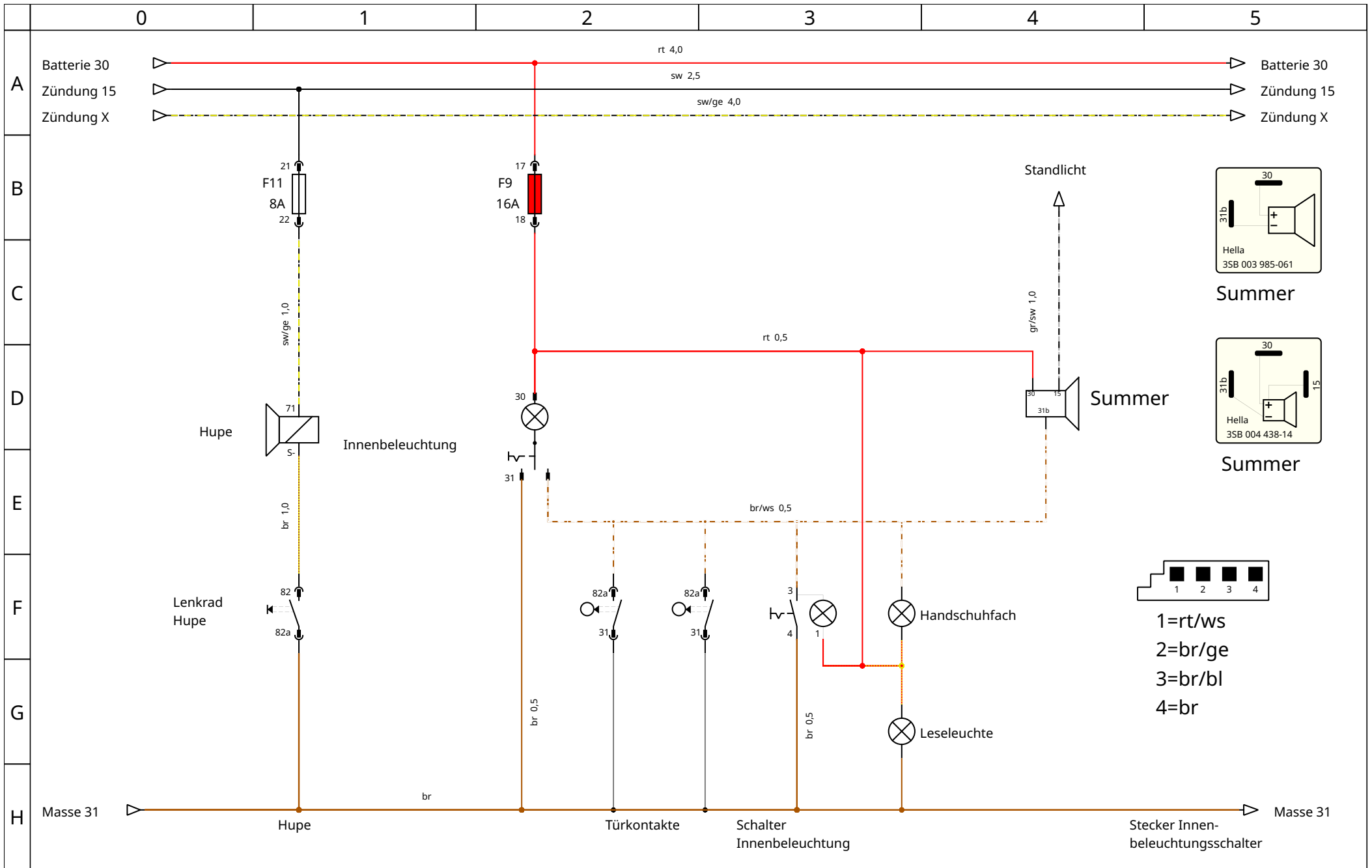

Author: Fuss-im-Ohr

Datum: 21.12.23

Hupe und Innenbeleuchtung

Projekt: Käfer

Seite: 21/32

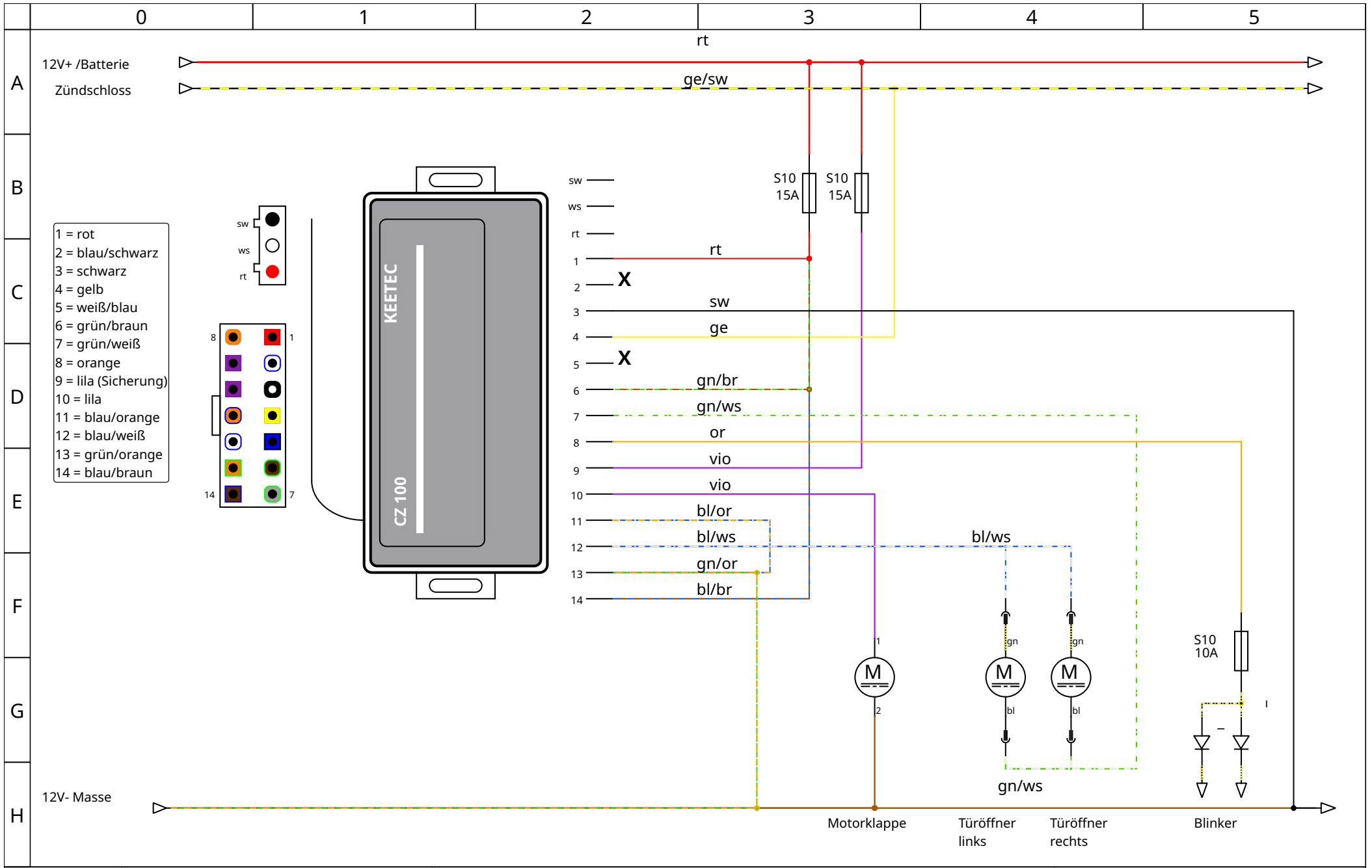

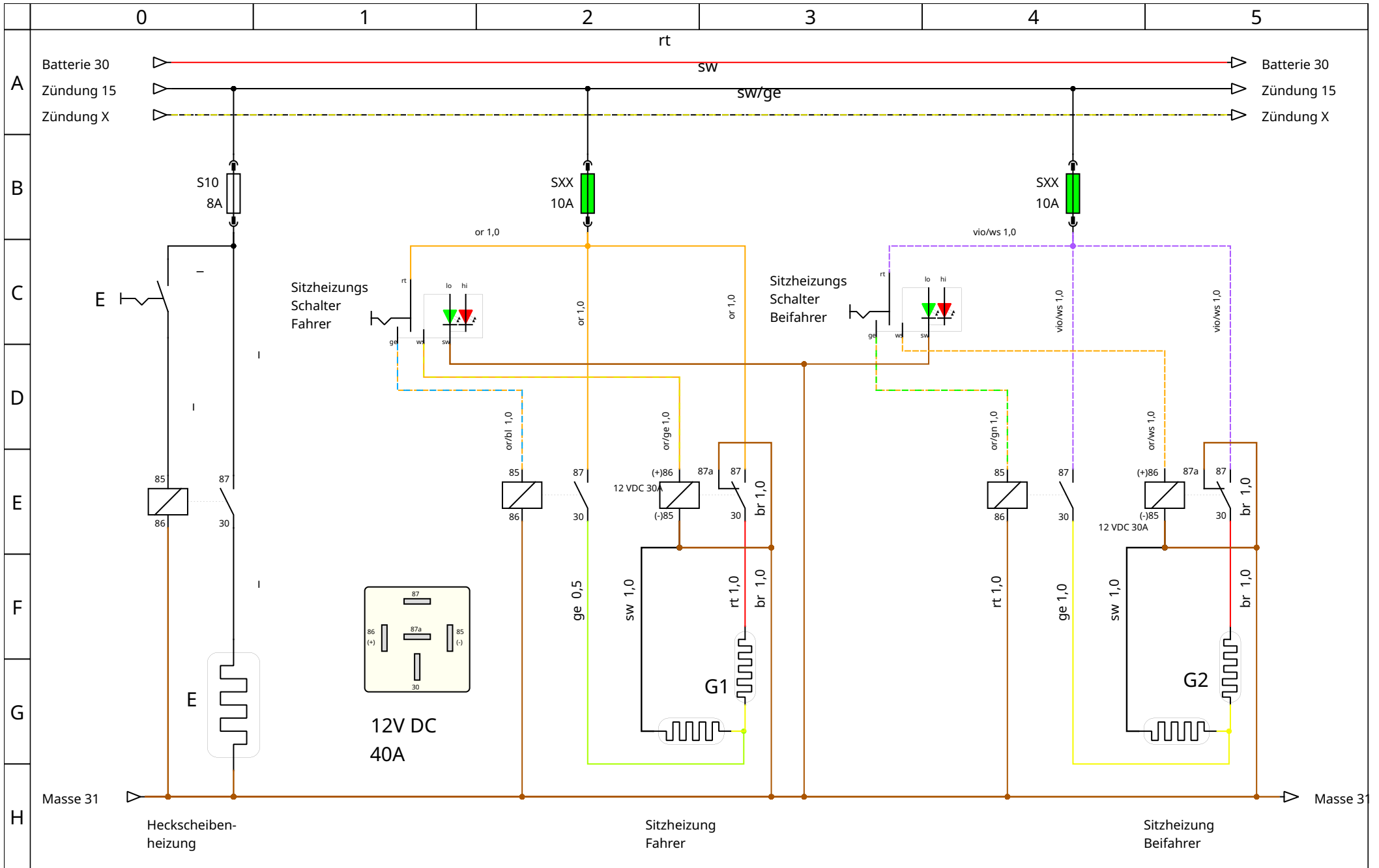

Author: Fuss-im-Ohr

Datum: 21.12.23

Sitz- und Heckscheibenheizung

Projekt: Käfer

Seite: 23/32

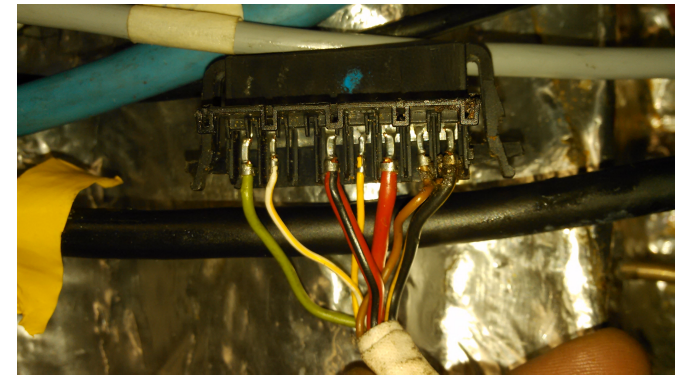

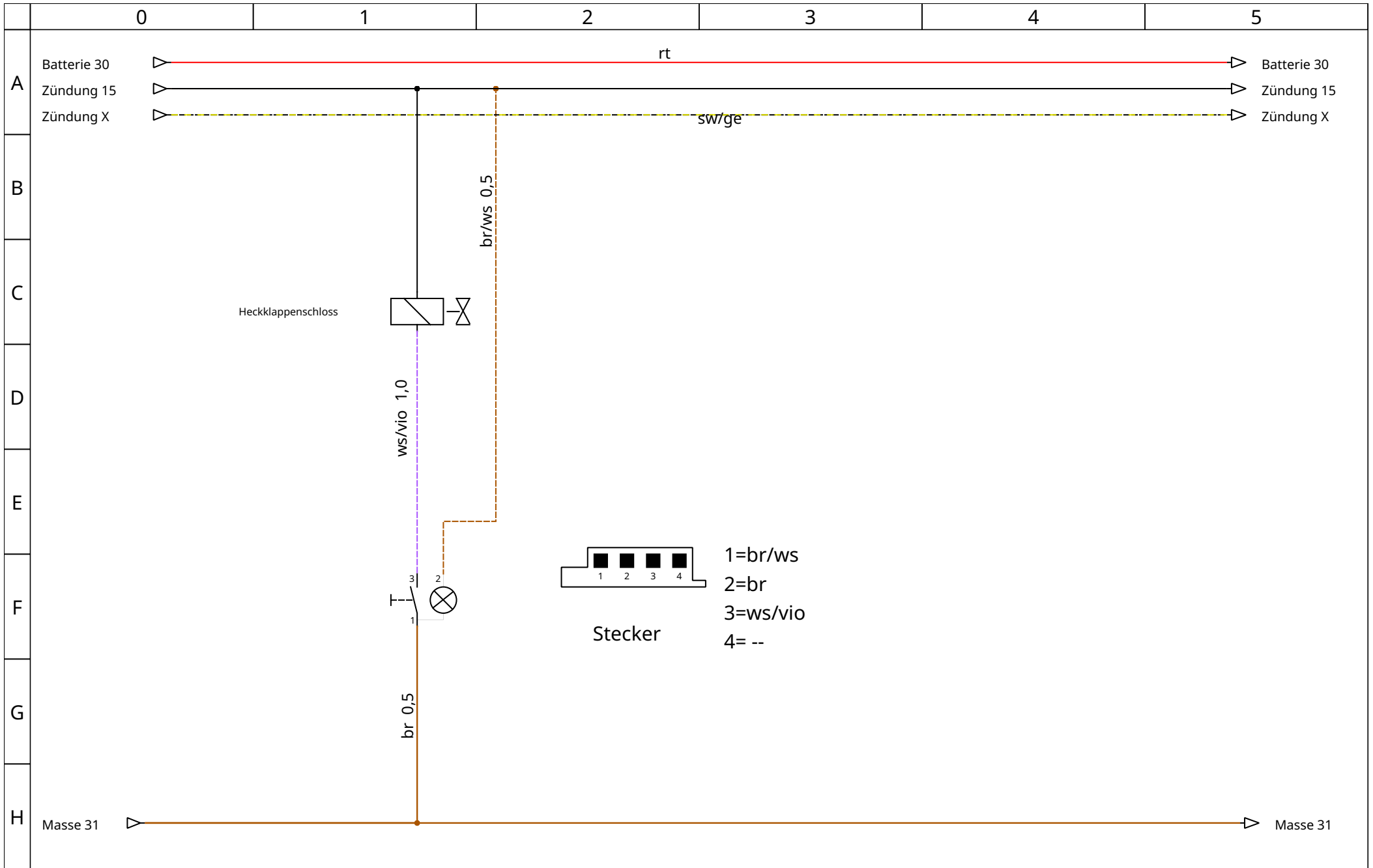

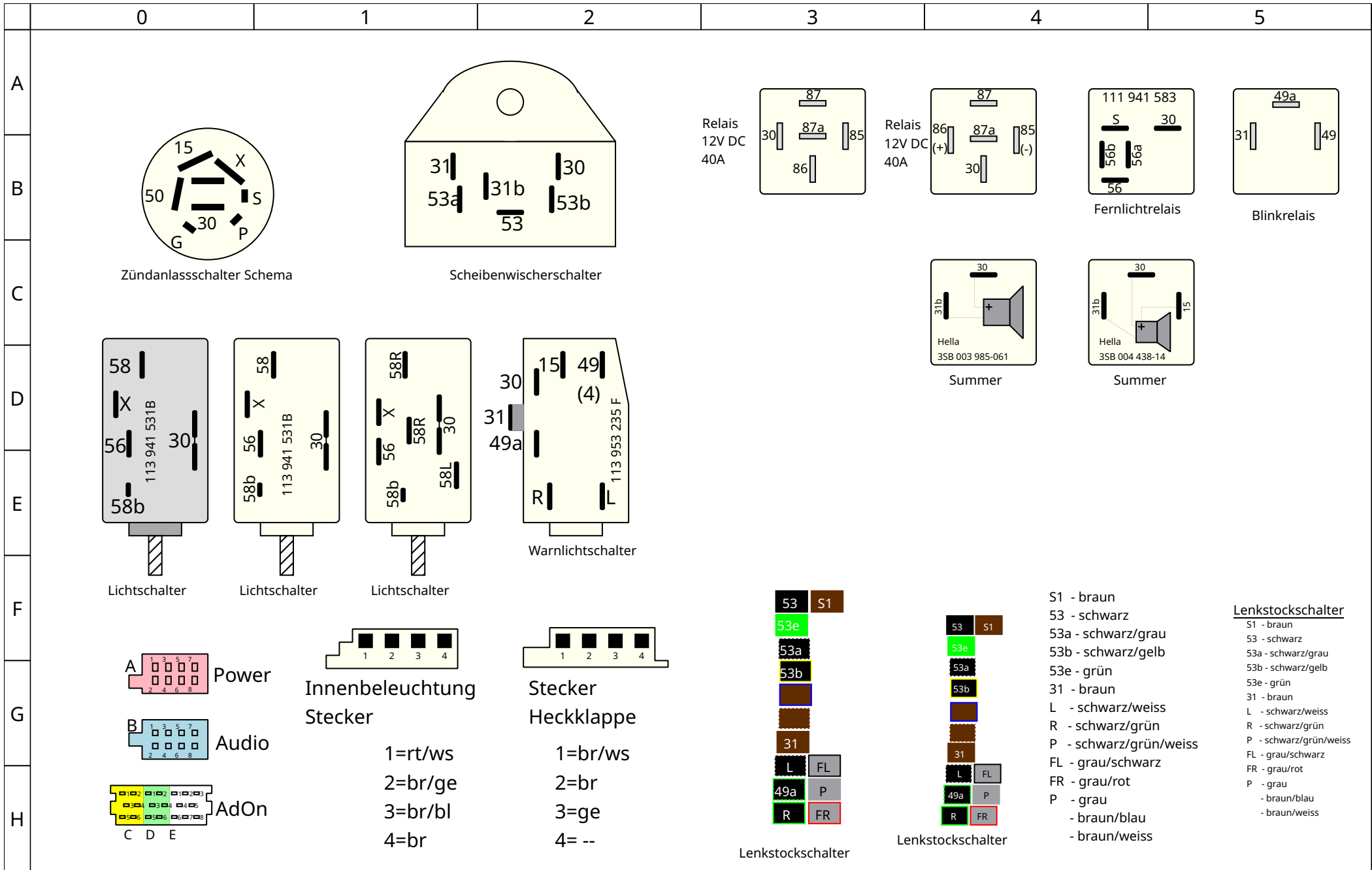

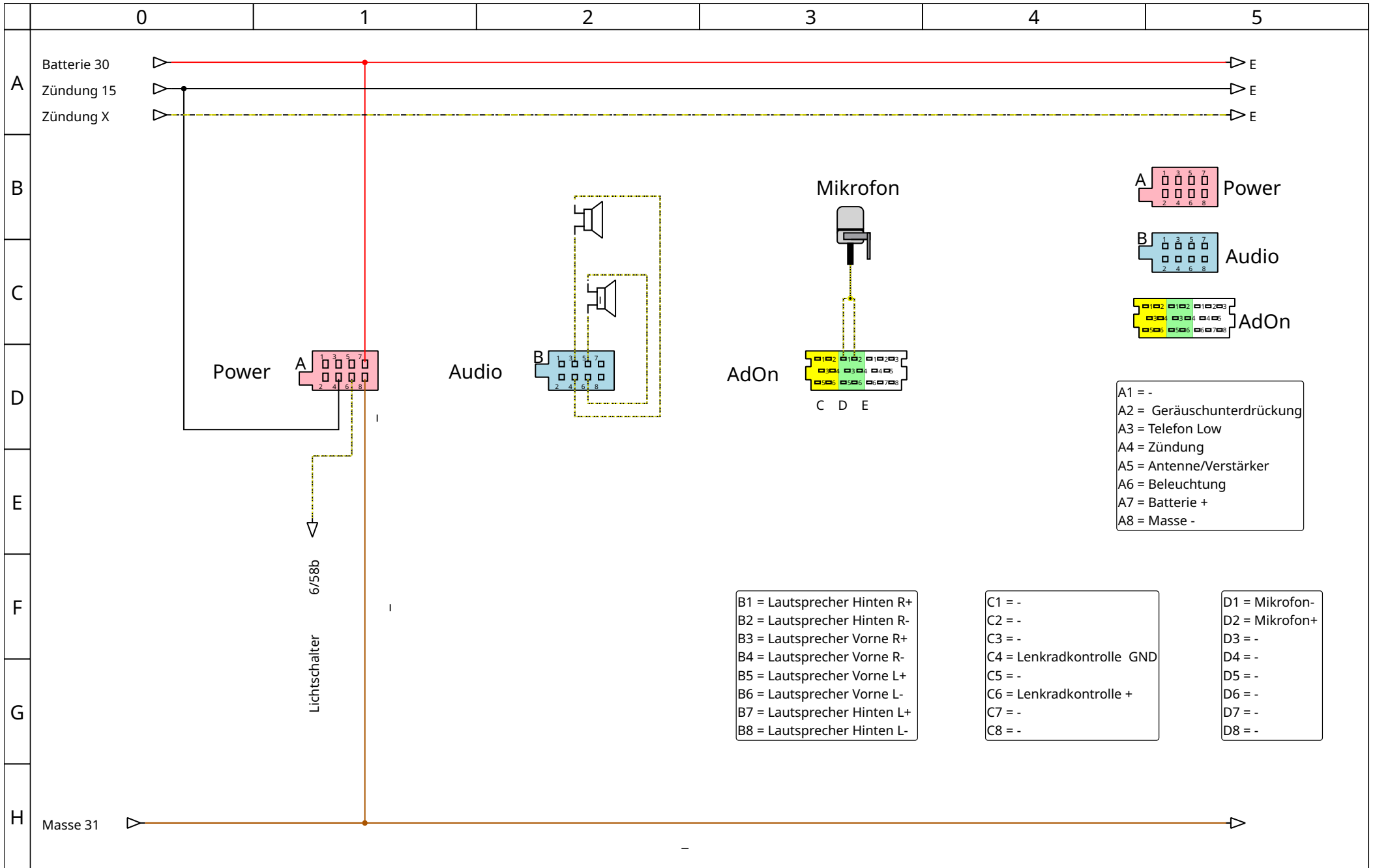

Author: Fuss-im-Ohr

Datum: 21.12.23

Radio

Projekt: Käfer

Seite: 27/32

0

1

2

3

4

5

A

B

C

D

E

F

G

H

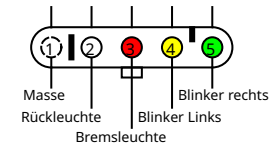
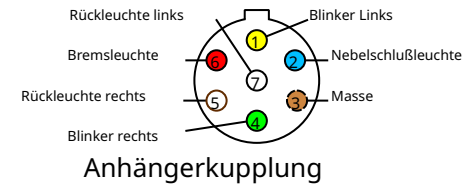
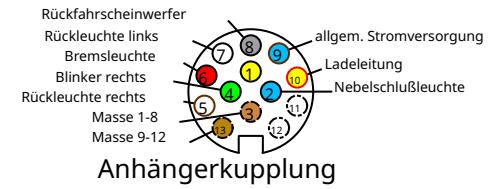

weiss	Masse
schwarz	Rücklicht
rot	Bremslicht
gelb	Blinker Links
grün	Blinker rechts



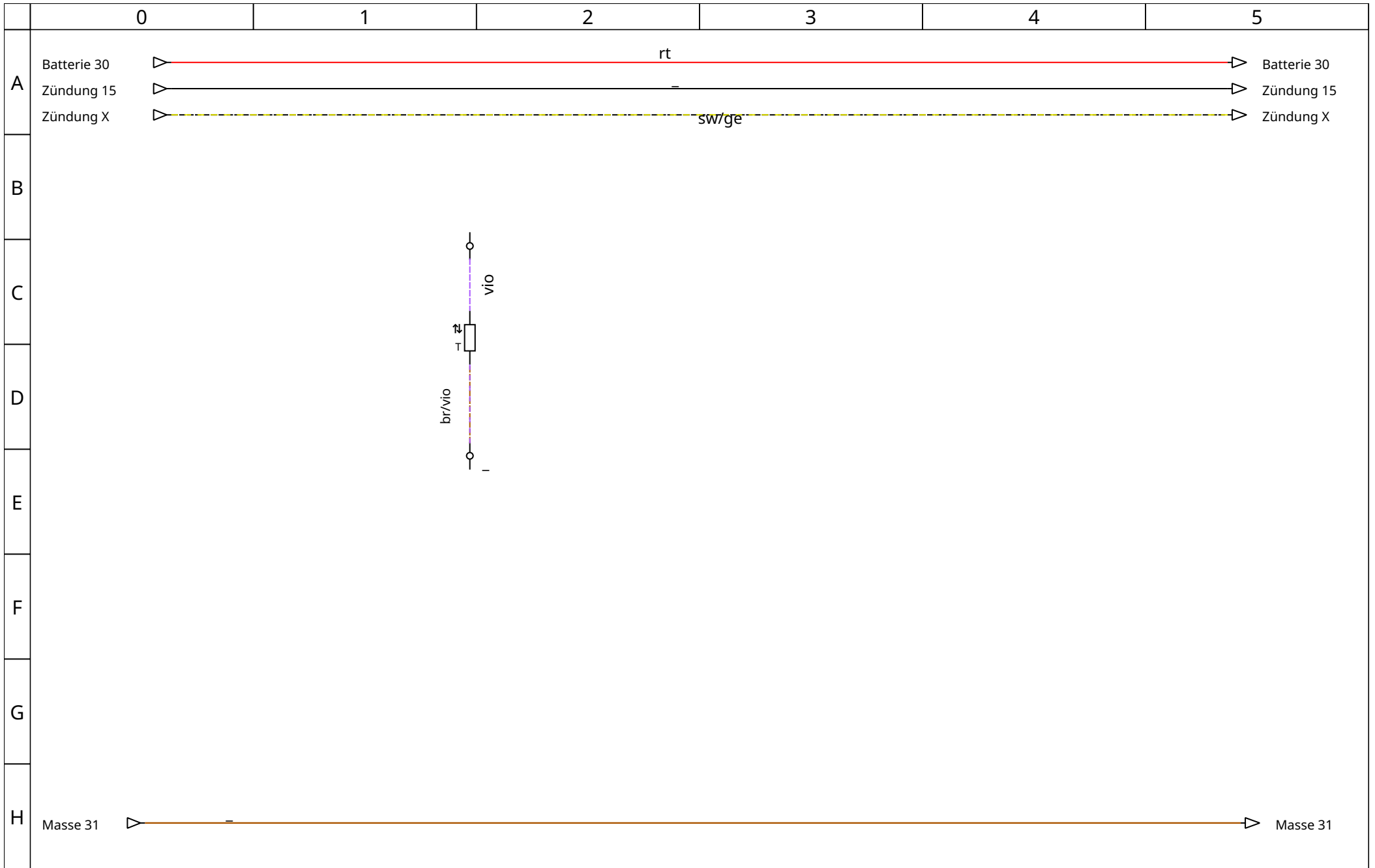

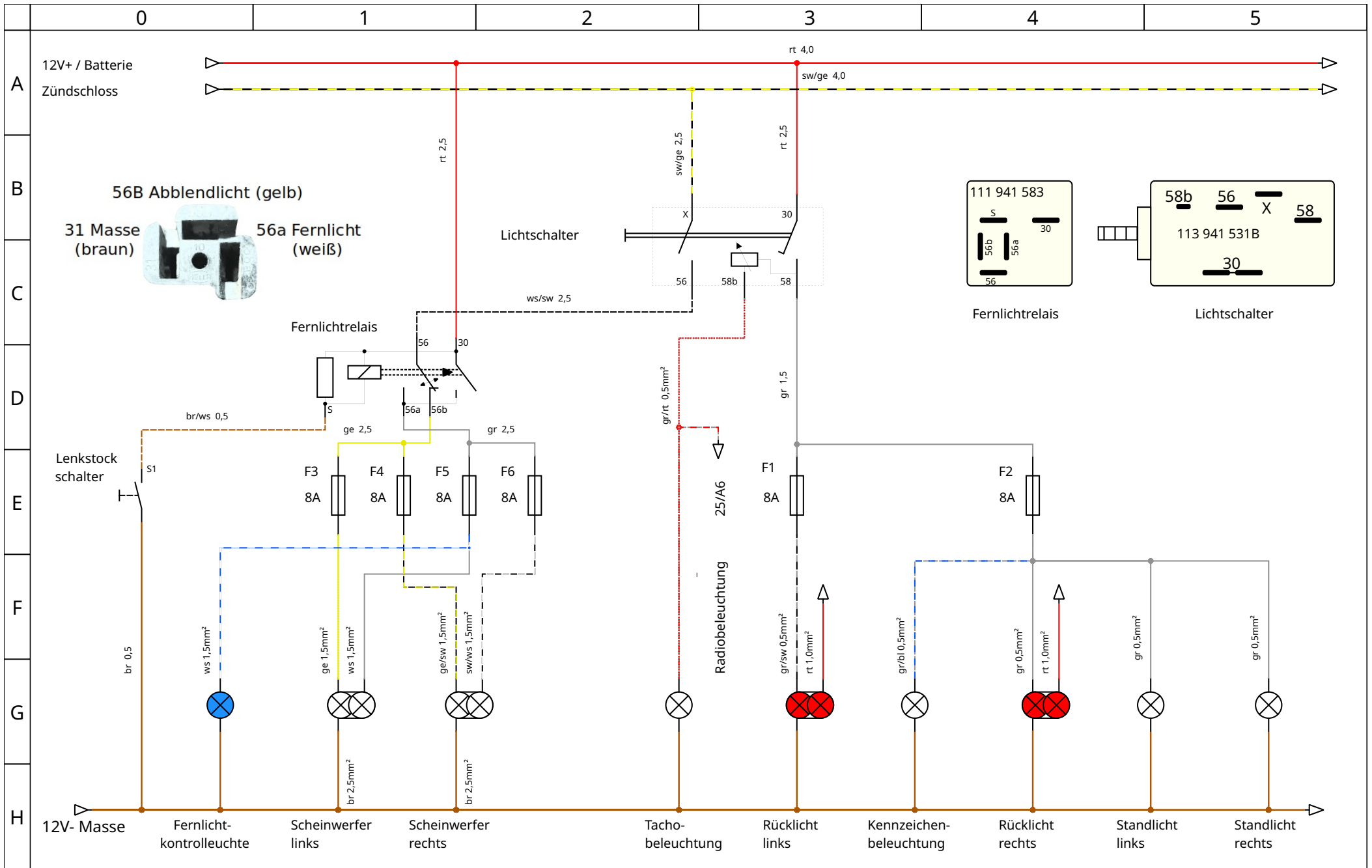

Author: Fuss-im-Ohr

Datum: 21.12.23

Lichtanlage vorne

Projekt: Käfer

Seite: 30/32



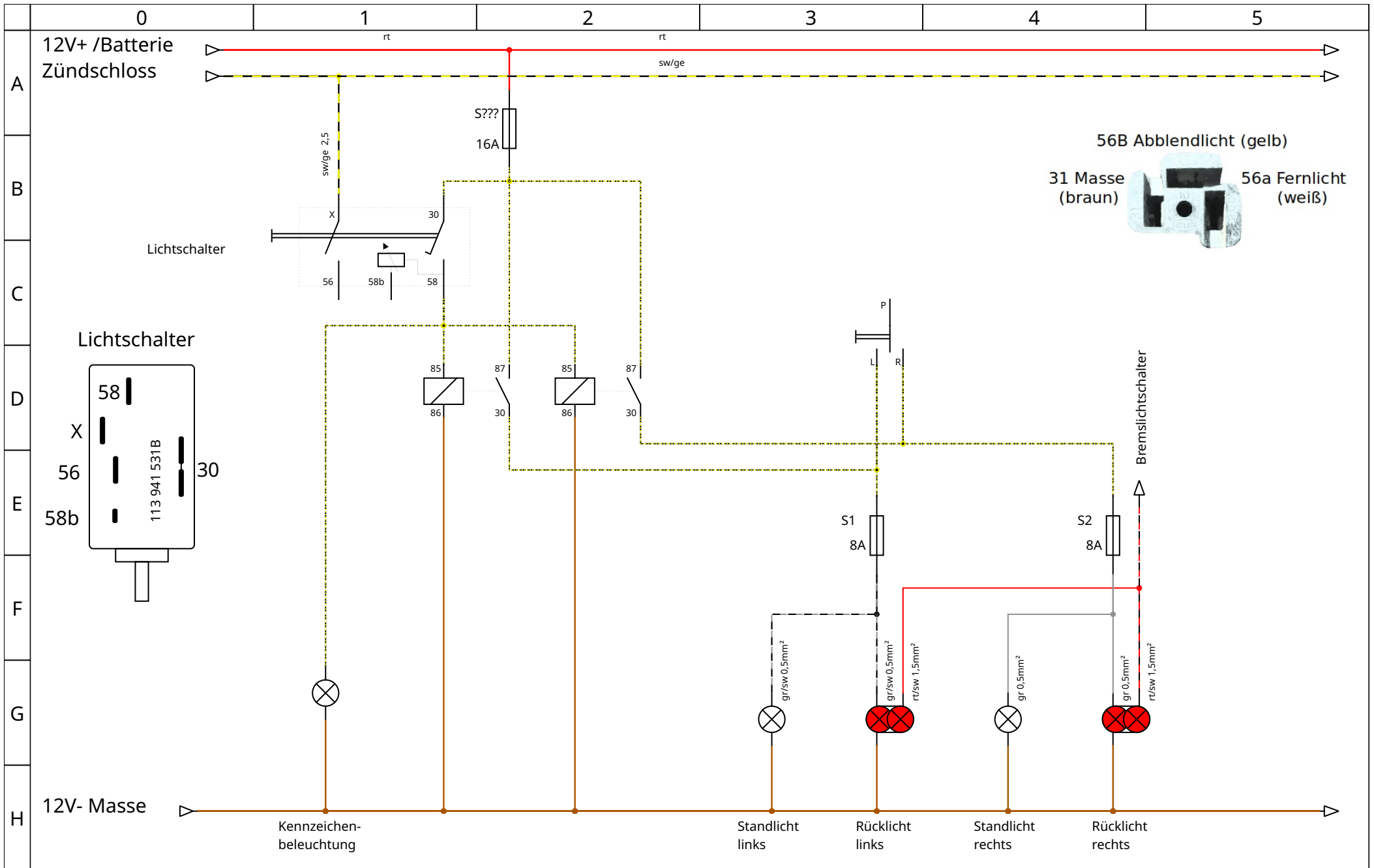

Author: Fuss-im-Ohr

Datum: 21.12.23

Stand-und Parklicht Spezial

Projekt: Käfer

Seite: 31/32



